

**Read installation instructions completely before installing.**

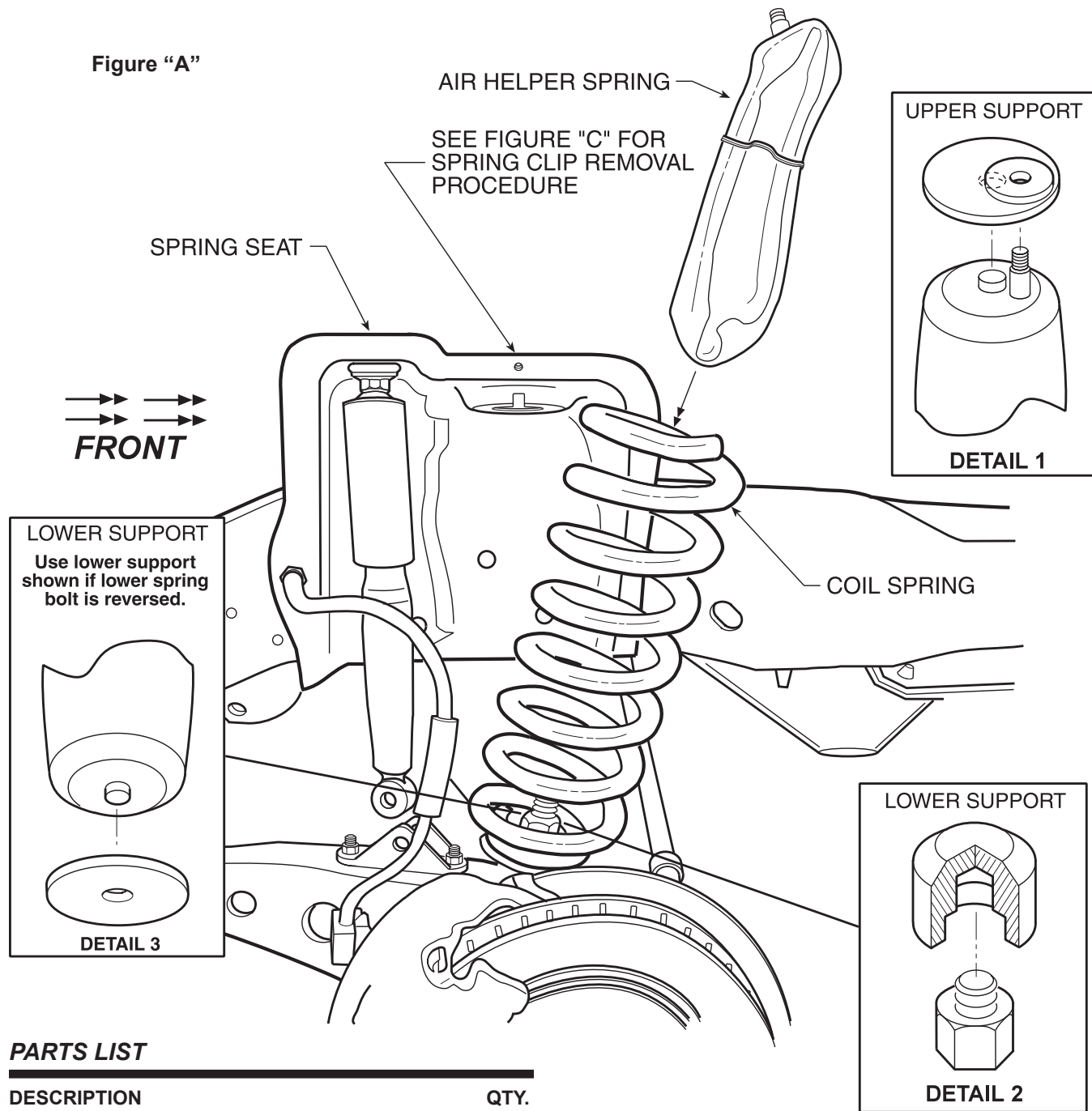

**PARTS LIST**

| DESCRIPTION                     | QTY. |
|---------------------------------|------|
| AIR SPRINGS                     | 2    |
| UPPER SUPPORTS                  | 2    |
| LOWER SUPPORTS (BOLT)           | 2    |
| LOWER SUPPORTS (NUT)            | 2    |
| 18' AIR LINE ASSEMBLY           | 1    |
| NYLON TIE                       | 6    |
| PUSH-TO-CONNECT INFLATION VALVE | 2    |
| 5/16" FLAT WASHER               | 4    |

**OPERATING PRESSURES**

|                               |              |
|-------------------------------|--------------|
| CLASS "C" MOTORHOME/1 TON VAN | 10-60 P.S.I. |
| PICKUP / SUV                  | 10-60 P.S.I. |
| E33 CLASS "A" MOTORHOME       | 30-60 P.S.I. |

# COIL-RITE AIR SPRING INSTALLATION PROCEDURE

READ INSTRUCTIONS COMPLETELY BEFORE INSTALLATION.

## WARNING

Do not inflate this assembly when it is unrestricted. The assembly must be restricted by a coil spring. Do not ever inflate beyond recommended operating pressures for your specific vehicle. Improper use or over inflation may cause property damage or severe personal injury.

**FIRESTONE INDUSTRIAL PRODUCTS  
CARMEL, INDIANA, USA**

## STEP 1 VEHICLE PREPARATION

With the vehicle on a solid level surface chock the rear wheels. Raise the vehicle using a lift or platform jack rated for your vehicles weight to lift the front wheels off the ground. Remove the front wheels. Lower the vehicle onto jack stands rated for your vehicles weight making sure the suspension is fully extended. (**Do not use wood or concrete blocks to support the weight of the vehicle.**)

## STEP 2 COIL SPRING PREPARATION

Remove the lower shock absorber bolt to allow the suspension to hang freely as shown in **Figure "B"**. The use of a hydraulic jack placed under the axle below the coil spring may be needed to relieve the tension on the shock.

Remove the clip holding the coil spring in the spring seat as shown in **Figure "C"**. This clip is located on the top of the coil spring and is attached to the upper coil spring seat. Tilt the coil spring so the top of the coil spring is exposed, **see Figure "A"**.

## STEP 3 AIR SPRING PREPARATION

Remove one air spring from your Coil-Rite kit. Depress the valve stem and deflate the air spring as much as possible. After deflating the air spring, roll it tightly lengthwise and hold in that position, **see Figure "A"**.

## STEP 4 INSTALLATION TO VEHICLE

Refer to **Figure "A"** throughout this step. With the valve stem pointed up, insert the rolled-up air spring into the top of the coil spring. Once the air spring is completely inside the coil spring, remove the valve stem and allow the air spring to return to its normal position.

Install the upper and lower supports as shown in **Details 1, 2 and 3 on Figure "A"**. Slide the lower support through the lowest point on the coil spring and place it over the nut and bolt on the lower spring seat or placed as shown in **Detail 3**. The upper support can be placed on top of the air spring through the open end of the coil spring.

## STEP 5 RE-ASSEMBLE SUSPENSION

Place the coil spring in its original position and re-attach the coil spring clip. Make sure the upper and lower supports have remained in the proper position. Attach the shock absorber to the suspension. You may need to use the hydraulic jack to raise the lower arm of the suspension. (**Be sure the clip is attached and secure before attempting this step.**)

## STEP 6 ROUTE THE AIR LINE

Remove the tubing from the hose kit and cut it into two equal lengths (cut the tubing as squarely as possible). Select a location for the inflation valves in a protected area, such as: under the hood or on the bumper (Note: inflation valve will be installed in Step 6). Route the air line from the air spring to the desired location of the inflation valve, **see Figure "E"**.

Attach the elbow fitting to the air spring and finger tighten, refer to **Figure "D"**. Route the air line from the air spring to the desired location of the inflation valve. **See Figure "E"**.

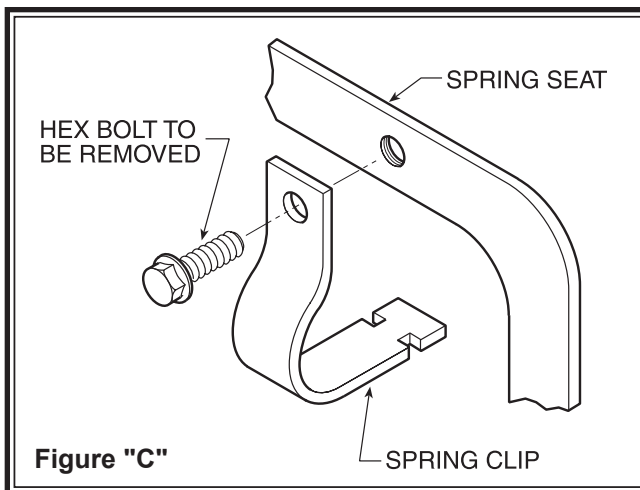
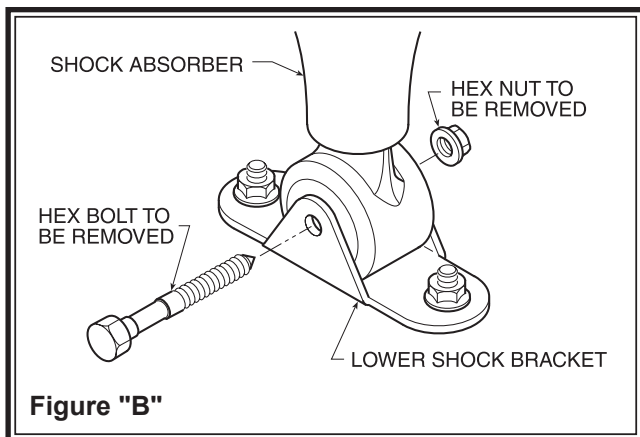

**PLEASE TAKE ALL NECESSARY SAFETY  
PRECAUTIONS WHEN INSTALLING YOUR  
COIL-RITE KIT.**

# EXTENSION HOSE INSTALLATION INSTRUCTIONS

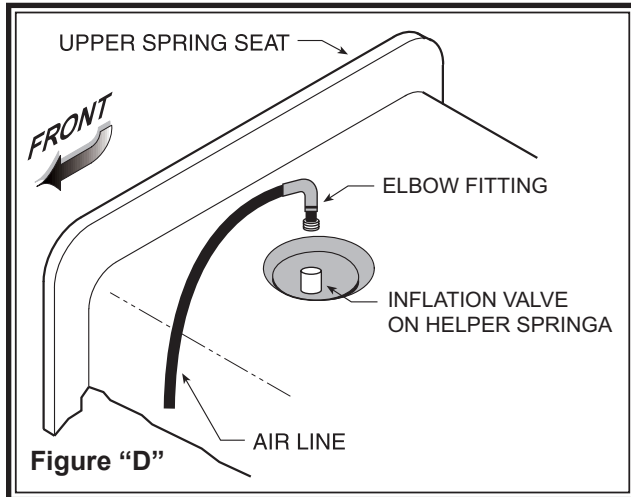

## STEP 7 HOSE ATTACHMENT TO THE VEHICLE

With the tubing routed from the air spring to the location of the inflation valve. Use the nylon ties supplied, secure the air line tubing to the vehicle as shown in **Figure "E"**. Be careful to avoid heat and sharp edges when fastening the tubing to the vehicle. Stay away from the radiator and exhaust system.

## STEP 8 INSTALLING THE INFLATION VALVE

Drill a 5/16" hole where you wish to mount the inflation valve. Remember to keep the inflation valve in a protected area that is easily accessible. Attach the inflation valve to the body of the vehicle as shown in **Figure "F"**. Tighten all nuts at this time.

Cut the excess air line tubing so that it will fit easily into the inflation valve, making sure the end is cut squarely (a "saw" cut with a sharp knife is preferred). Push the end of the tubing into the inflation valve as far as possible.

## FOLLOW STEPS 2-8 FOR THE OTHER AIR SPRING.

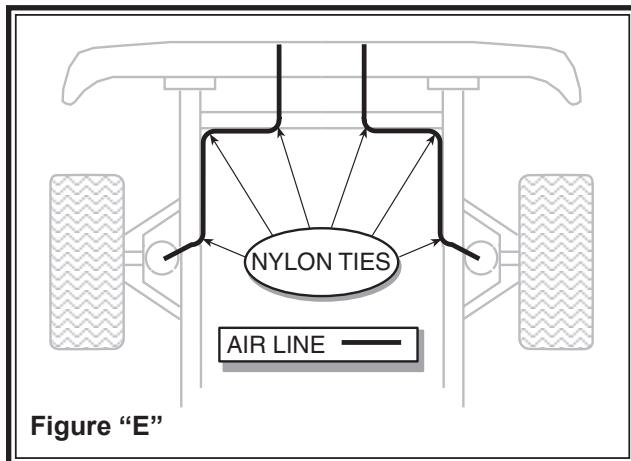

## STEP 9 INFLATE AND TEST

Inflate the air springs to recommended operating pressure (see Page 1 for operating pressures). With a soap and water solution, check for air leaks around the fittings and valve core. Jack up the vehicle, remove the jack stands and lower the vehicle to the ground. We recommend inflating and deflating in 5 p.s.i. increments to find the ideal riding condition for your vehicle.

**NOTE:** Check air pressure on a monthly basis.

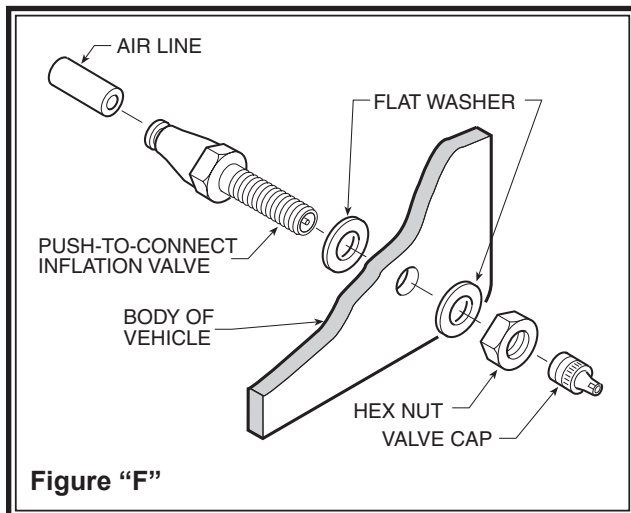

**FOR MORE INFORMATION OR  
TECHNICAL ASSISTANCE CALL:  
1-800-888-0650**



# Do Not Return This Product to the Dealer or Distributor

## If you are

- missing parts,
- experiencing installation problems, or
- have technical concerns regarding this product,

you may contact a Firestone Technical Service Representative at [rrtech@fsip.com](mailto:rrtech@fsip.com) or at 800-888-0650 (option 1, and then option 2). Representatives are available from 7:30 a.m. – 4:30 p.m. Eastern on Monday – Friday, excluding holidays. If you are located outside of the United States, you should first contact your distributor or dealer directly with any issues.

When contacting Technical Service, please have the kit or part # ready, along with the make, model, and year of the vehicle. You may also need to provide details, such as 2WD/4WD or if the vehicle has been lifted or lowered from stock height.

If you have a warranty concern, please include in your email a detailed description of the situation, a photo(s) of the issue, and your contact information, including ship-to address.

**WARRANTY COVERAGE\***— The Ride-Rite™ kits, components, and accessories are warranted against defects in workmanship and materials. This warranty does not cover service or labor charges, neglect...to the product.

### **PERIOD OF COVERAGE:**

- |   |  |
|---|--|
| • Ride-Rite air springs – Lifetime Limited  | • Work-Rite load assists – 2 Years Limited                                       |
| • Sport-Rite air springs – Lifetime Limited | • Air-Rite accessories – 2 Years Limited   |
| • Coil-Rite air springs – Lifetime Limited  | • Brackets, hardware, fittings, air line, and other components – 2 Years Limited |
| • Level-Rite air springs – Lifetime Limited |  |

**HOW TO MAKE A WARRANTY CLAIM** — If you purchased your air springs in the U.S. or Canada and believe you have a part with a warrantable defect, call Firestone directly at 1-800-888-0650.

International customers should contact their distributors or dealers directly with any problems.

(\*) Please refer to the “Firestone Limited Lifetime Air Spring Warranty” for details, terms, and conditions.

## **WARRANTY QUESTIONS**

Go to [www.riderite.com/installation-support](http://www.riderite.com/installation-support)  
Select “Warranty Info” tab