

# 7010

# Firestone

# AIRSTROKE™

ACTUATORS

# AIRMOUNT™

ISOLATORS

Description		Assembly Order No.
Style 7010	Blind nut, 1/8 NPT	W02-358-7010
Two Ply Bellows		
Assembly weight .....		1.6 lbs.

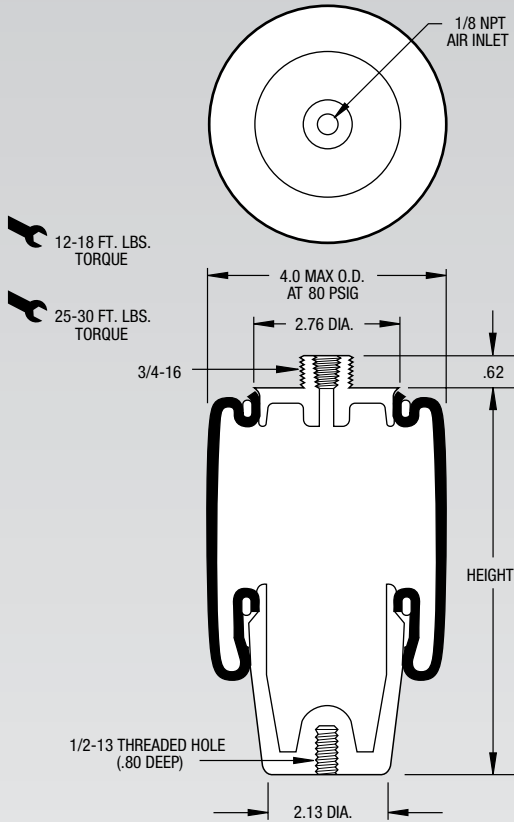

**NOTE:** Bellows will not compress properly with less than 10 PSIG internal pressure.

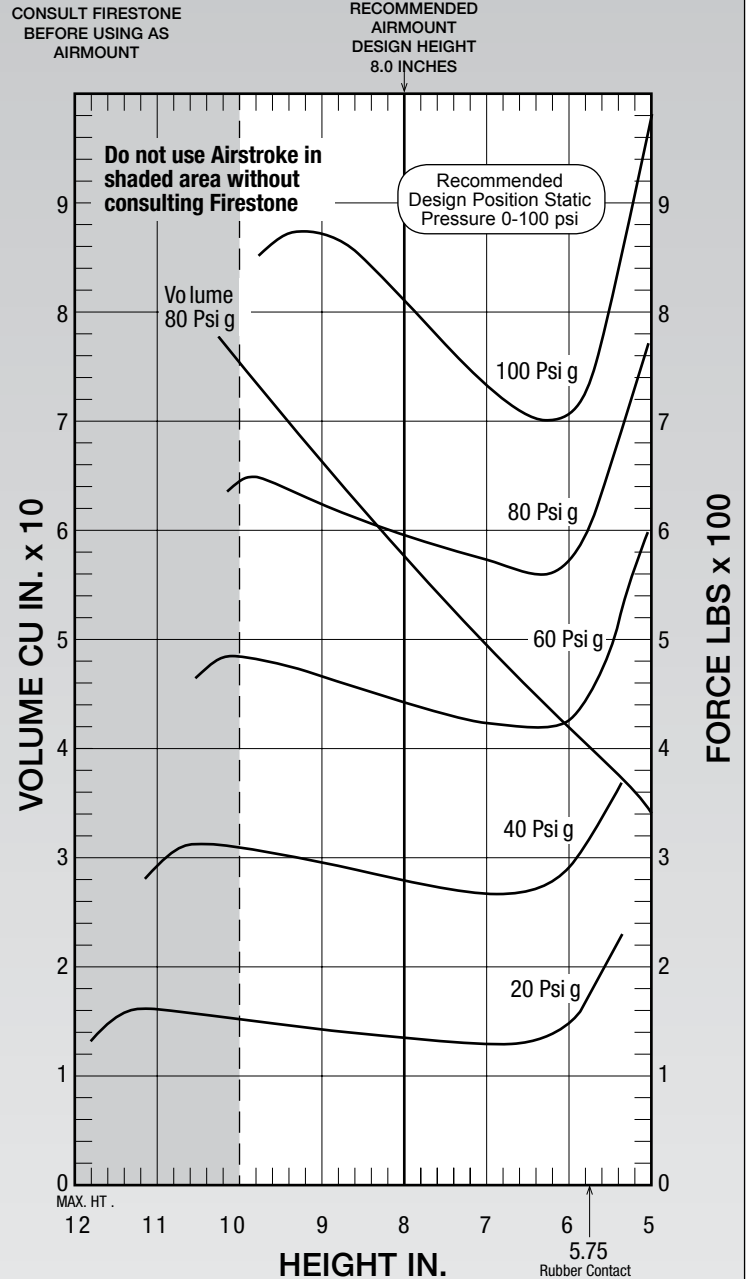

See page 12 for instructions on how to use chart.

Dynamic Characteristics at 8.0 in. Design Height (Required for Airmount isolator design only)				
Volume @ 80 PSIG = 58 in <sup>3</sup>			Natural Frequency	
Gage Pressure (PSIG)	Load (lbs.)	Spring Rate (lbs./in.)	CPM	HZ
40	280	62	88	1.47
60	440	89	84	1.40
80	600	116	83	1.38
100	810	107	68	1.13

Force Table (Use for Airstroke™ actuator design)						
Assembly Height (in.)	Volume @ 80 PSIG (in <sup>3</sup> )	Pounds Force				
		@20 PSIG	@40 PSIG	@60 PSIG	@80 PSIG	@100 PSIG
10.0	75	150	310	480	650	880
9.0	67	140	300	470	630	870
8.0	58	140	280	440	600	810
7.0	50	130	270	430	580	740